

Rev	Description	By	Date
1	Preliminary	SO	31-May-23

ELECTRICAL SPECIFICATIONS @ 25°C

L: 110μH±15% @ 10kHz, 1Vrms
 100uH Min @ 45Arms
 DCR: 15.5mΩ Max
 Hipot: 3kVdc, 1mA Max, 10s (wdgs to core)
 Operating Temp: -40°C to 125°C
 Storage Temp: -40°C to 125°C
 RoHS Compliant: Yes

DIMENSIONS

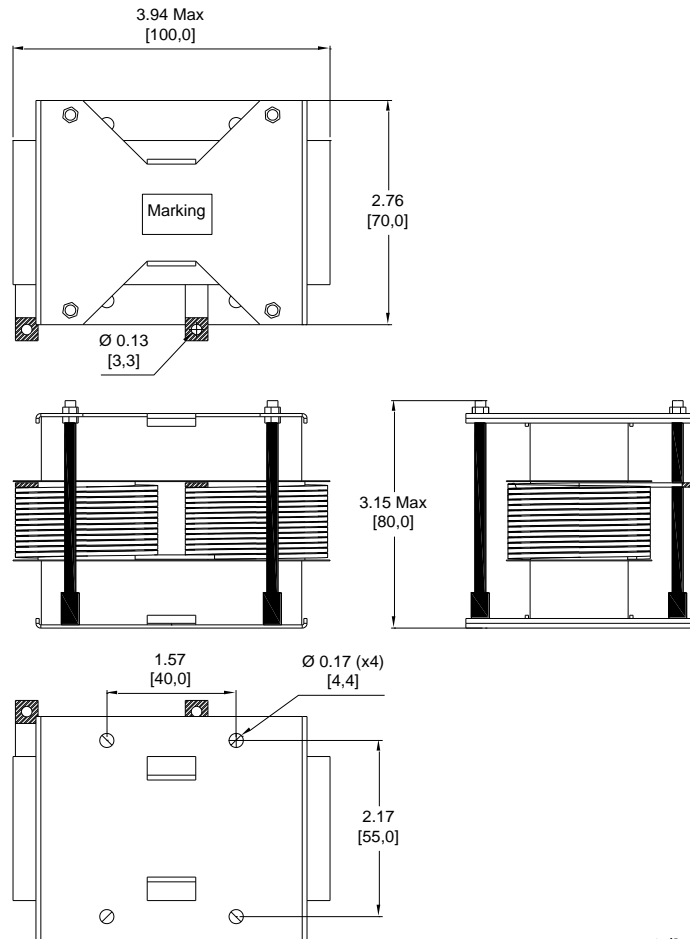

Dimensions: inch/[mm]

SCHEMATIC

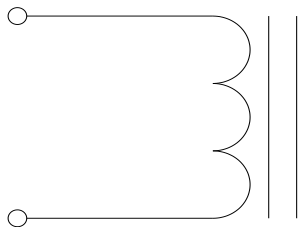

MARKING

MPS
 HWI28P1-045-111B_ Rev#
 Date Code

NOTES

 MPS INDUSTRIES, INC. www.mpsind.com Tel: (310) 325-1043 Fax: (310) 325-1044		Description			
		100uH Interface Filter Inductor			
Notice of Proprietary Property These drawings and specifications are the property of MPS and shall not be, reproduced, copied or used as the basis of manufacture of sale of apparatus without express written authorization		Part Number	REV		
Dimensions Unless otherwise specified .XX ± .010" [0,254mm] .XXX ± .005" [0,13mm]		DRAWN BY: CHECKED BY:	SO SO 31-May-23 31-May-23 A	HWI28P1-045-111B WEIGHT: 1320 gms SHEET: 1 OF 1	1